



ELECTRIC FUEL PUMPS
P/N 12-801-1, 712-801-1, 12-802-1, 12-802-2, 712-802-1, 12-812, 12-815-1, & 712-815-1

FUEL PRESSURE REGULATORS
P/N 12-500, 12-501, 12-803, 12-803BP, 12-804, & 15812NOS

Installation Instructions 199R7914-3

NOTE: 12-803BP IS NOT TO BE USED WITH MECHANICAL FUEL PUMPS!

WARNING! These instructions must be read and fully understood before beginning the installation. Failure to follow these instructions may result in poor performance, vehicle damage, personal injury, or death. If these instructions are not fully understood, installation should not be attempted.

APPLICATIONS:

<i>P/N</i>	<i>DESC</i>	<i>FLOWS</i>	<i>PRESSURE REGULATOR</i>	<i>ALC / METH COMPAT.</i>	<i>PRESET PRES- SURE</i>	<i>SAFETY SWITCH SHUT-OFF</i>
12-801-1	Red Electric Fuel pump, Street Perf.	97 gph (free flow) 67 gph at 5 psi	Not required for most applications	No	7 PSI	Recommended (P/N 12-810)
712-801-1	Red Electric Fuel Pump, Marine	97 gph (free flow) 67 gph at 5 psi	Not required for most applications	No	7 PSI	Recommended (P/N 12-810)
12-802-1	Blue Electric Fuel Pump, Competition	110 gph (free flow) 70 gph at 9 psi	High pressure (12-803 provided)	No	14 PSI	Recommended (P/N 12-810)
712-802-1	Blue Elec. Fuel Pump, Comp. Marine	110 gph (free flow) 70 gph at 9 psi	High pressure (12-803 provided)	No	14 PSI	Recommended (P/N 12-810)
12-812	Blue Electric Fuel Pump, Competition	110 gph (free flow) 70 gph at 9 psi	Low pres. (use 12-804) High pres. (use 12-803) High press. bypass (use 12-803BP)	No	14 PSI	Recommended (P/N 12-810)
12-815-1	Black Elec. Fuel pump, Pro Series	140 gph (free flow) 120 gph at 9 psi	Requires P/N 12-704	Yes	14 PSI	Recommended (P/N 12-810)
712-815-1	Black Elec. Fuel pump, Pro Series Marine	140 gph (free flow) 120 gph at 9 psi	Requires P/N 12-704	Yes	14 PSI	Recommended (P/N 12-810)

<i>P/N</i>	<i>DESCRIPTION</i>	<i>PRESSURE RANGE</i>	<i>INLET/OUTLET SIZE</i>	<i>RESTRICTION</i>
12-803	High-Pressure Fuel Regulator (std. finish)	4-1/2 to 9 PSI	3/8" NPT Ports	.220" (7/32")
12-501	High-Pressure Fuel Regulator (chrome finish)			
15812NOS	High-Pressure Fuel Regulator (std. finish)	4-1/2 to 9 PSI	3/8" NPT Ports	.220" (7/32")
12-804	Low-Pressure Fuel Regulator (std. finish)	1 to 4 PSI	3/8" NPT Ports	.220" (7/32")
12-500	Low-Pressure Fuel Regulator (chrome finish)			
12-803BP	Low-Pressure Bypass Regulator (std. finish)	4 to 7 PSI	3/8" NPT Ports	.312" (5/16")

INTRODUCTION:

Congratulations on your purchase of the Holley Fuel Pump, Holley Regulator, or NOS Regulator! Holley Performance Products cannot and will not be responsible for any alleged or actual engine or other damage, or other conditions resulting from misapplication of the parts described herein. However, it is our intent to provide the best possible products for our customer; products that perform properly and satisfy your expectations. Should you have any questions, please call Tech Support at 1-866-GOHOLLEY, M-F, 7-5 CST. Please have the part number on hand of the product when you call.

The electric fuel pump in this instruction sheet is of the vane rotor type. Holley makes three versions: a low-pressure pump meets the flow requirements of most passenger vehicles. The high-pressure pump is used mainly for high performance applications and comes with a fuel pressure regulator. The second high-pressure pump allows an even higher flow rate and is alcohol and methanol compatible, but contains no fuel pressure regulator. A separate fuel pressure regulator must be purchased. The mounting holes are untapped on the above Holley and NOS regulators. Use the supplied self-tapping screws.

PUMP MOUNTING AND INSTALLATION:

The best location for mounting any electric fuel pump is the rear of the vehicle. The inlet and outlet of the pump must be mounted below the lowest point of the tank. This is necessary to allow for an adequate fuel supply. The pump is designed to push fuel and not designed to suck fuel out of the tank. It needs to be gravity-fed or if it's pulling from the top of the tank, it needs to develop a siphon feed to the pump. The pump should be mounted on the chassis, in a vertical position with the pump motor on top. Avoid exposure of the pump and fuel lines to moving parts and to any hot areas, such as the exhaust manifold. The pump should not be mounted in a closed area, such as the vehicle's trunk. Follow the steps below for mounting the pump.

WARNING! THE PUMP MUST BE LOCATED SO THAT INTERFERENCE BETWEEN THE VEHICLE'S BODY AND ITS CHASSIS MOVEMENT IS AVOIDED. THE PUMP AND ITS CONNECTING HOSES MUST NOT BE SUBJECTED TO LOW GROUND CLEARANCE, WHERE ANY FLYING ROCKS OR ROAD DEBRIS CAN CAUSE DAMAGE. FAILURE TO AVOID THESE HAZARDS WILL LEAD TO PUMP DAMAGE, WHICH COULD RESULT IN FIRE, PROPERTY DAMAGE, SERIOUS INJURY, AND/OR DEATH.

1. Select a mounting site as close as possible to the fuel supply and away from possible sources of heat, as detailed previously.
2. Use the mounting bracket (supplied) as a template and drill two clearance holes for 5/16" bolts.
3. Place the rubber gaskets (supplied) between the mounting bracket and motor housing and mount the pump in the vertical position (motor on top) using two 5/16" bolts.
4. Connect the fuel line from the tank to the fuel filter and the filter to the inlet port of the pump. Connect the carburetor delivery line to the outlet port of the pump. Use the same size flexible hose as original equipment. Avoid unnecessary restrictions such as sharp bends and undersized fuel fittings and hoses. Avoid routing fuel lines in areas that would cause chafing. All fuel line connections must be leakproof.

WARNING! DO NOT OVERTIGHTEN THE FITTINGS ON THE FUEL PUMP OR REGULATOR. ASSEMBLY TORQUE SHOULD NOT EXCEED 40 FT./LBS. THIS CAN BE ACHIEVED BY HAND TIGHTENING THE FITTING, FOLLOWED BY WRENCH TIGHTENING AN ADDITIONAL 3/4 OF 1 TURN AND THE AMOUNT NECESSARY TO POSITION THE FITTING IN THE CORRECT ORIENTATION. OVERTIGHTENING OF THE FITTINGS CAN CAUSE PARTS TO CRACK, ALLOWING FUEL TO LEAK. A FUEL LEAK CAN CAUSE A FIRE AND/OR EXPLOSION RESULTING IN PROPERTY DAMAGE, SERIOUS INJURY, AND/OR DEATH. THE USE OF A THREAD SEALANT WITH TEFLON IS HIGHLY RECOMMENDED. DO NOT USE A SILICONE-BASED SEALANT OR TEFLON TAPE.

NOTE: For performance vehicles, 3/8" I.D. hose is recommended. We strongly urge the use of a coarse screen-type filter before the pump and a high quality filter after the pump.

NOTE: Marine 712- fuel pumps have a fume tube on the base of the pump, this tube should be hooked to a direct vacuum source on the engine. This is a safety feature for marine that in the case of a fuel leak internally in the pump, the fuel will be pulled into the engine and not leak into the engine compartment.

5. If the Mechanical Fuel Pump is not going to be used or removed, disconnect the fuel lines from the pump and securely plug the inlet and discharge ports with plugs to deactivate the pump. Connect the original suction line to the outlet line, bypassing the pump from the circuit.
6. If the Mechanical Fuel Pump is removed, seal the opening with a suitable metal cover and gasket.

USING A FUEL PRESSURE REGULATOR WITH A FUEL PUMP:

NOTE: If the pump is a high-pressure model, a pressure regulator must be installed in the line between the pump and the carburetor.

NOTE: The mounting holes are untapped on these regulators. Use the supplied self-tapping screws.

1. Using the bracket supplied with the regulator, position the regulator as close to the carburetor as possible, taking care to minimize the exposure to heat sources. **DO NOT** mount the regulator on the exhaust manifold or any extremely hot surface.
2. The standard regulator, provided with the 12-802-1 pump, has two discharge (out) ports (see Figure 1). In dual carburetor installations, one port can feed each carburetor. With single carbs, plug one port and feed the carburetor from the other. Either may be used. Installations should determine choice. See Figure 1.
3. The 12-803BP bypass regulator has one bypass or return port. This port (labeled "RET") must be connected to the storage tank with a fuel line the same size as the supply line (3/8" I.D. is recommended). See Figures 2a & 2b.

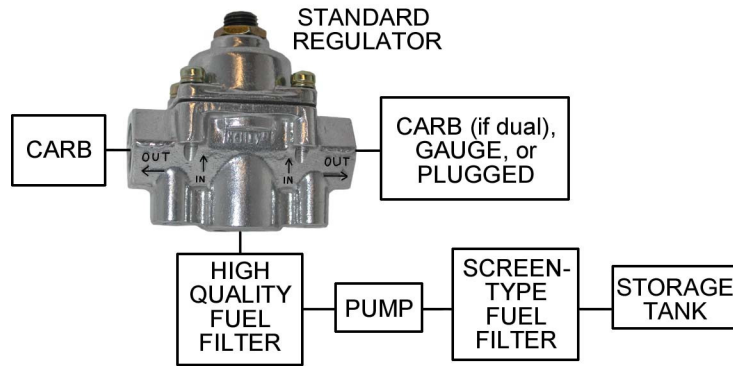

Figure 1

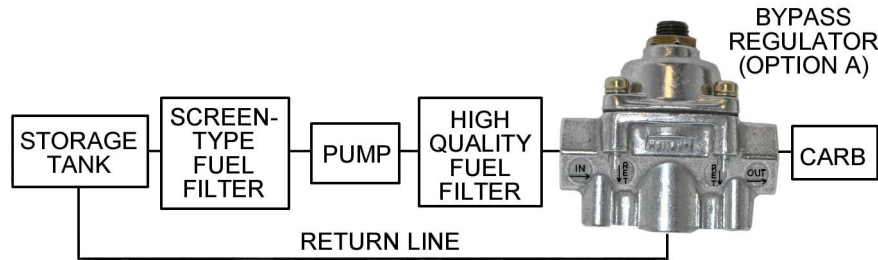

Figure 2a

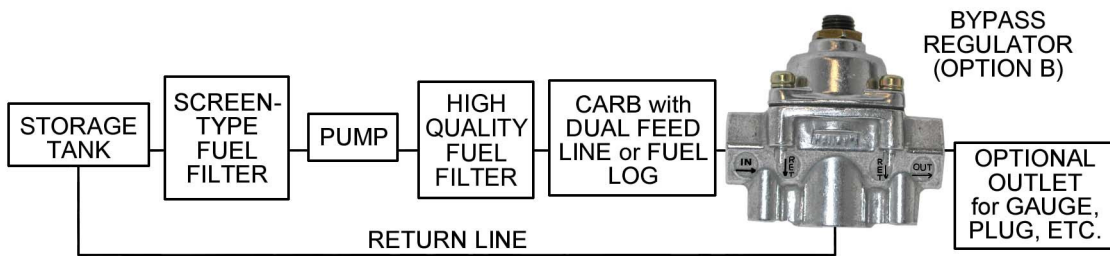

Figure 2b

4. Connect the fuel line from the “out” side of the pump to the “in” side on the regulator. All fuel line connections must be leakproof.
5. Connect the other line per Figure 2a or 2b.
6. The regulator comes from Holley with the regulator pressure preset (see table). However, for individual requirements, it may be readjusted. Loosening the regulator locknut and turning the adjustment screw clockwise increases the pressure. Decrease pressure by turning the adjustment screw counter-clockwise.

WARNING! TURNING THE ADJUSTMENT SCREW ALL THE WAY IN WILL RESULT IN EXCESSIVE FUEL PRESSURE AND CAUSE THE CARBURETOR TO FLOOD. A FLOODED CARBURETOR CAN CAUSE A FIRE AND/OR EXPLOSION RESULTING IN PROPERTY DAMAGE, SERIOUS INJURY, AND/OR DEATH. ALWAYS USE A FUEL PRESSURE GAUGE BETWEEN THE REGULATOR AND THE CARBURETOR(S) WHEN ADJUSTING THE FUEL PRESSURE REGULATOR.

NOTE: Any change made in fuel pressure will change the fuel bowl float level requirements. A readjustment in fuel bowl levels will be required for proper operation of the fuel system.

WIRING THE FUEL PUMP:

NOTE: A fuel pump can be wired as shown in Figure 3, but the preferred method is wiring it through a relay, as shown in Figure 4.

1. Disconnect the ground cable from the battery.
2. Connect the fuel pump (red lead) to a 12-volt ignition source. In this line, add an in-line fuse holder and a 7.5 amp fuse.

- To complete the installation, connect the ground (black lead) to the battery.

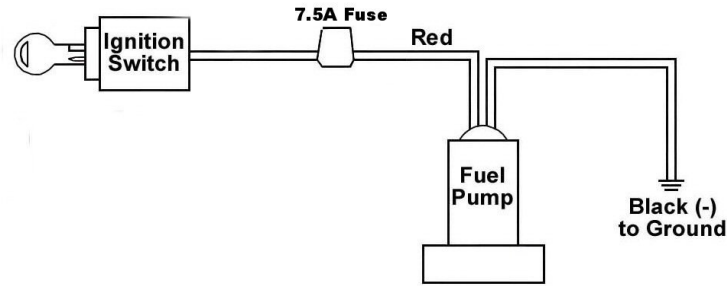

Figure 3

WIRING THE FUEL PUMP WITH A RELAY:

NOTE: You will need Holley Fuel pump relay kit P/N 12-753 or equivalent 4-wire relay.

- Disconnect the cables from the battery.
- Mount relay on firewall of engine compartment using a sheet metal screw.

WARNING! Before punching or drilling a hole in the firewall, make sure you know what is on the other side to avoid puncturing equipment such as heater cores, air-conditioning system equipment, hoses, or wiring.

- Plug the fuel pump relay harness into the relay, until it locks into place.
- Connect the black wire of the harness to ground.
- Connect the Green/Black wire to a switched 12V source.
- Connect one of the red wires to the positive wire (red wire) of the fuel pump.
- Attach the in-line fuse holder to the remaining red wire. After attaching the fuse holder, insert the 15A fuse and connect to the positive side of the battery.
- Reconnect the battery cables.

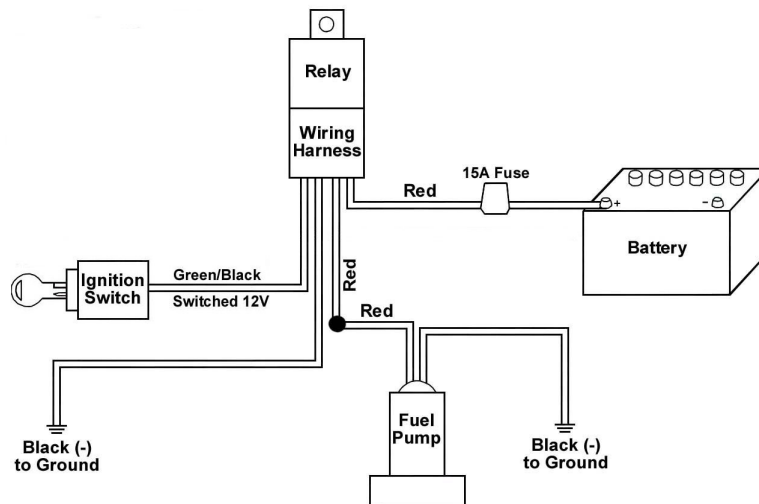

Figure 4

WIRING THE FUEL PUMP WITH A OIL PRESSURE SAFETY SWITCH:

One method is to wire the pump to a switched 12-volt source (providing power only when the engine is running) located at the vehicle's electric panel. To ensure this condition, the installation of a Holley 12-810 oil pressure safety switch is recommended for installation into the wiring circuit. This will ensure that the pump will not continue to operate after the engine is shut off and/or when the key is left in the "ON" position. If the pressure switch is to be used, follow the installation instructions as outlined below (refer to Figure 5).

1. Disconnect the ground cable from the battery.
2. Remove the original equipment oil pressure switch and retain.
3. Screw a 1/8" pipe nipple into the hole from which the original pressure switch was removed. Use any suitable thread sealant on all fittings, taking care to avoid any excess that might contaminate the engine.
4. Screw a 1/8" pipe tee onto the nipple and position it in a manner to facilitate the installation of the original oil pressure switch and the new oil pressure safety switch in the remaining two holes.
5. Screw in the two switches and reconnect the lead to the original equipment oil pressure switch.

NOTE: The pump oil pressure switch will normally have three terminals marked: C (common), NC (normally closed), and NO (normally open).

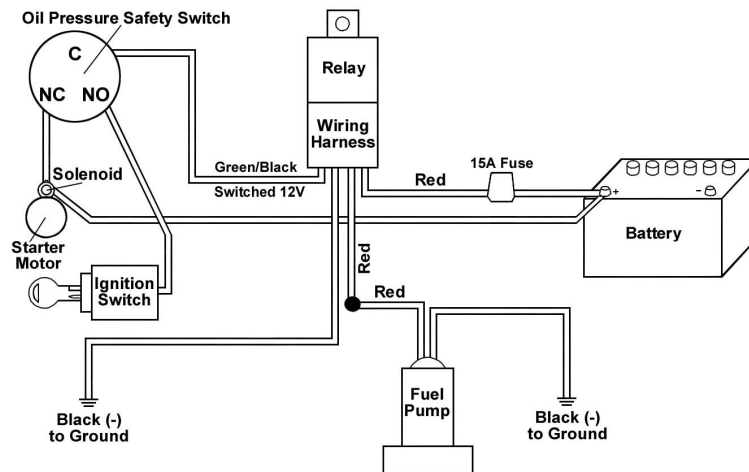

Figure 5

6. Connect the fuel pump (red lead) to the terminal marked "C". In this line, add an in-line fuse holder and a 15-amp fuse.
7. Connect the terminal marked "NO" to the on terminal of the ignition switch.
8. Connect the terminal marked "NC" to the starter terminal that's hot (12V) during cranking only.
9. To complete the installation, connect the ground cable to the battery.

WARNING! USE A MINIMUM OF 14 GAUGE WIRE. BE SURE TO CRIMP ALL ELECTRICAL CONNECTORS SECURELY AND CLEAN ANY AREA WHERE GROUND LEADS WILL BE FASTENED. FAILURE TO USE THE MINIMUM WIRE GAUGE COULD RESULT IN A PUMP MALFUNCTION AND/OR ELECTRICAL FIRE, RESULTING IN PROPERTY DAMAGE, SERIOUS INJURY, AND/OR DEATH.



Oil Pressure Safety Switch
P/N 12-810



Fuel Pressure
For High Performance Pump P/N 12-803



Fuel Pressure Regulator
For High Performance Pump P/N 12-704

MAINTENANCE AND CLEANING INSTRUCTIONS FOR ELECTRIC FUEL PUMPS:

Due to the current poor quality gasoline that's available, it is recommended that periodically a can of dry gas be used to absorb the water out of the fuel delivery system. The fuel filter element should be blown clean with compressed air every 6,000 miles and replaced every 12,000 miles to assure maximum protections. If your fuel pump fails to pump or fails to maintain adequate pressure, check the following:

1. Check the voltage at the pump to ensure 12-volt supply.
2. Check the fuel line (especially the fuel filter) for any obstruction. Use compressed air to blow the line free.
3. If this doesn't solve the problem, turn the pump on and listen for a hum from the top of the pump. If there is no hum, the pump's electrical system should be checked by a competent repairman. If the pump hums, it probably only needs to be cleaned.

CLEANING THE PUMP:

The following is a step-by-step procedure for cleaning the Holley electric fuel pumps. Do all disassembling on a clean bench. Read all instructions thoroughly and completely before starting.

1. Remove the pump from the car.
2. Remove the 5 bolts from the bottom of the pump.
3. Holding the pump in position, remove the bottom plate. Remove the upper plate gasket and rotor stop plate. Note the position of the rotor, rotor vanes, flame arrestor (screen), and relief valve arrangement for re-installation.

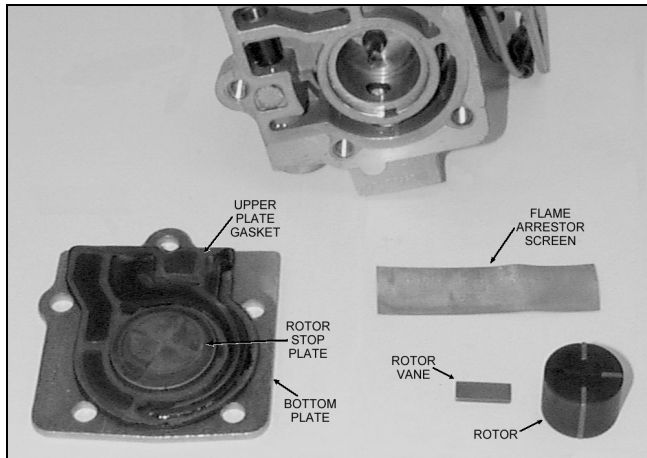

Figure 6

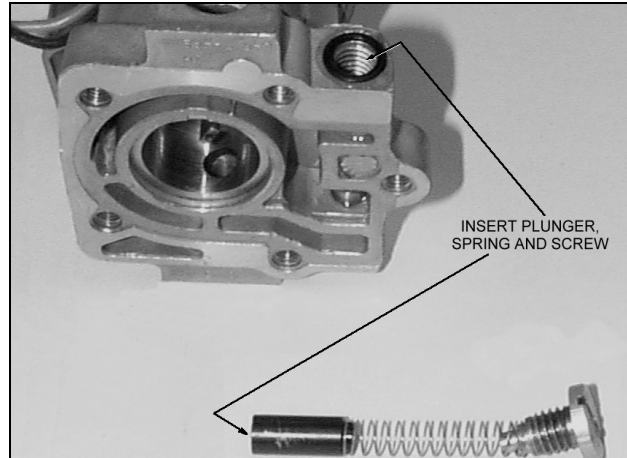

Figure 7

4. Remove the flame arrestor (note the position of the screen). Remove the rotor vanes and rotor by inverting the pump. Lay all pieces on a flat clean surface. See Figure 6.
5. Remove the pressure relief screw. The screw is spring loaded. Remove the spring and relief plunger.
6. Clean the base housing with any good quality carburetor cleaner (spray-type only). Blow the base dry with compressed air. Clean any loose Teflon tape, etc. from the inlet and outlets.

WARNING! DO NOT IMMERSE THE ENTIRE UNIT IN ANY LIQUID. IMMERSION COULD DAMAGE THE ELECTRICAL CIRCUITRY, RESULTING IN A PUMP MALFUNCTION. A PUMP MALFUNCTION COULD RESULT IN A FIRE, WHICH MAY RESULT IN PROPERTY DAMAGES, SERIOUS INJURY, OR DEATH.

7. If the relief plunger is rusty, clean it with emery paper. The plunger must slide freely in the base. Check the plunger, spring, and o-ringed screw. Check that plunger is free in the slide. See Figures 7 and 8.

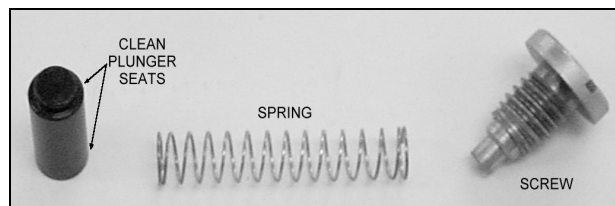

Figure 8

8. Clean the rotor vanes with emery paper. The vanes must slide freely in the rotor slot. Check that the vanes move freely. Replace the rotor stop plate. Install the flame arrestor making sure the screen is behind the screen stop. Replace the upper plate gasket and upper plate. Fasten with five screws.
9. Replace the pump in the car.