



ADJUSTABLE PROPORTIONING VALVE

PART NUMBER: 260-8420

SPECIFICATIONS:

MAX PRESSURE REDUCTION	57%
INLET / OUTLET PORTS	1/8-27 NPT
MOUNTING HOLE DIAMETER	.250 INCH
MOUNTING HOLE SPACING	1.00 INCH
WEIGHT	6.1 OUNCES

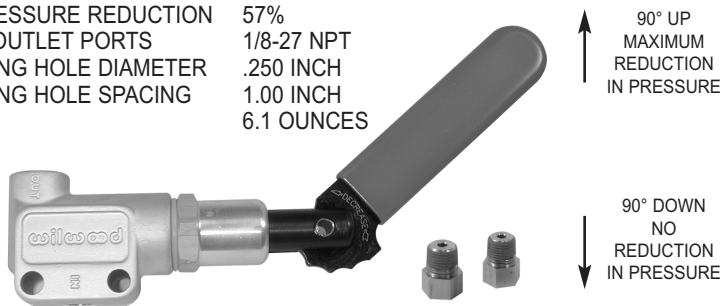

WARNING

IT IS THE RESPONSIBILITY OF THE PERSON INSTALLING ANY BRAKE COMPONENT OR KIT TO DETERMINE THE SUITABILITY OF THE COMPONENT OR KIT FOR THAT PARTICULAR APPLICATION. IF YOU ARE NOT SURE HOW TO SAFELY USE THIS BRAKE COMPONENT OR KIT, YOU SHOULD NOT INSTALL OR USE IT. DO NOT ASSUME ANYTHING. IMPROPERLY INSTALLED OR MAINTAINED BRAKES ARE DANGEROUS. IF YOU ARE NOT SURE, GET HELP OR RETURN THE PRODUCT. YOU MAY OBTAIN ADDITIONAL INFORMATION AND TECHNICAL SUPPORT BY CALLING WILWOOD AT (805) 388-1188, OR VISIT OUR WEB SITE AT WWW.WILWOOD.COM. USE OF WILWOOD TECHNICAL SUPPORT DOES NOT GUARANTEE PROPER INSTALLATION. **YOU**, OR THE PERSON WHO DOES THE INSTALLATION MUST KNOW HOW TO PROPERLY USE THIS PRODUCT. IT IS NOT POSSIBLE OVER THE PHONE TO UNDERSTAND OR FORESEE ALL THE ISSUES THAT MIGHT ARISE IN YOUR INSTALLATION.

RACING EQUIPMENT AND BRAKES MUST BE MAINTAINED AND SHOULD BE CHECKED REGULARLY FOR FATIGUE, DAMAGE, AND WEAR.

INSTALLATION & ADJUSTMENTS - Proportioning valves are normally installed in the rear fluid line to prevent the rear wheels from locking before the front wheels, or to give a driver the ability to make fine adjustments in front to rear bias percentage on the track to compensate for tire wear, fuel load burn-off, or changing track conditions. It is generally not recommended to attempt to reduce front wheel braking capacity.

Use only the two .25" body holes to secure the valve to a mount. Do not attempt to remove the adjuster lever or valve body end cap to facilitate thru-panel mounting.

Two 1/8-27 NPT to 3/8-24 inverted flair fittings are supplied to adapt double flared hard brake lines to the valve. Connect the "IN" port to the pressure line coming from the master cylinder. Connect the line going to the calipers to the "OUT" port.

Moving the adjuster lever until it is parallel with the body will provide full pressure delivery to the calipers. Moving the lever toward perpendicular to the body will incrementally reduce line pressure up to 57% when the valve is fully out. If this range of adjustment is not sufficient to properly balance the vehicle's bias, changes to other components within the system may be necessary.

TESTING THE SYSTEM - Do not attempt to operate the vehicle until the system has been fully tested under controlled conditions in a safe location. After the system has been bled, checked for leaks, and the proper pedal resistance and travel have been determined, make a series of low speed stops, then gradually progress to normal operating speeds.

WARNING - Adjustable proportioning valves are designed for tuning and balancing custom brake systems on performance, racing, and other types of special purpose vehicles. They are not designed as direct replacements for any OEM application.

4700 Calle Bolero • Camarillo, CA 93012 • Phone 805 / 388-1188 • www.wilwood.com

DS-489B REV DATE: 01-14-09



ADJUSTABLE PROPORTIONING VALVE

PART NUMBER: 260-8420

SPECIFICATIONS:

MAX PRESSURE REDUCTION	57%
INLET / OUTLET PORTS	1/8-27 NPT
MOUNTING HOLE DIAMETER	.250 INCH
MOUNTING HOLE SPACING	1.00 INCH
WEIGHT	6.1 OUNCES

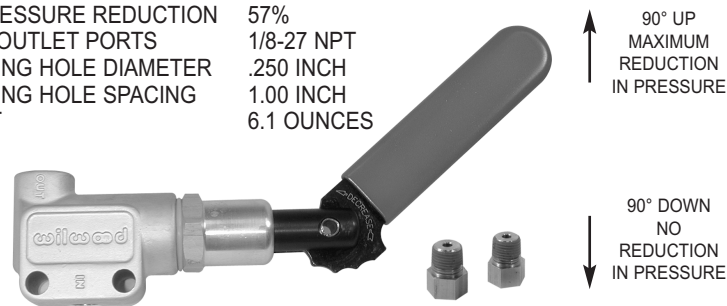

WARNING

IT IS THE RESPONSIBILITY OF THE PERSON INSTALLING ANY BRAKE COMPONENT OR KIT TO DETERMINE THE SUITABILITY OF THE COMPONENT OR KIT FOR THAT PARTICULAR APPLICATION. IF YOU ARE NOT SURE HOW TO SAFELY USE THIS BRAKE COMPONENT OR KIT, YOU SHOULD NOT INSTALL OR USE IT. DO NOT ASSUME ANYTHING. IMPROPERLY INSTALLED OR MAINTAINED BRAKES ARE DANGEROUS. IF YOU ARE NOT SURE, GET HELP OR RETURN THE PRODUCT. YOU MAY OBTAIN ADDITIONAL INFORMATION AND TECHNICAL SUPPORT BY CALLING WILWOOD AT (805) 388-1188, OR VISIT OUR WEB SITE AT WWW.WILWOOD.COM. USE OF WILWOOD TECHNICAL SUPPORT DOES NOT GUARANTEE PROPER INSTALLATION. **YOU**, OR THE PERSON WHO DOES THE INSTALLATION MUST KNOW HOW TO PROPERLY USE THIS PRODUCT. IT IS NOT POSSIBLE OVER THE PHONE TO UNDERSTAND OR FORESEE ALL THE ISSUES THAT MIGHT ARISE IN YOUR INSTALLATION.

RACING EQUIPMENT AND BRAKES MUST BE MAINTAINED AND SHOULD BE CHECKED REGULARLY FOR FATIGUE, DAMAGE, AND WEAR.

INSTALLATION & ADJUSTMENTS - Proportioning valves are normally installed in the rear fluid line to prevent the rear wheels from locking before the front wheels, or to give a driver the ability to make fine adjustments in front to rear bias percentage on the track to compensate for tire wear, fuel load burn-off, or changing track conditions. It is generally not recommended to attempt to reduce front wheel braking capacity.

Use only the two .25" body holes to secure the valve to a mount. Do not attempt to remove the adjuster lever or valve body end cap to facilitate thru-panel mounting.

Two 1/8-27 NPT to 3/8-24 inverted flair fittings are supplied to adapt double flared hard brake lines to the valve. Connect the "IN" port to the pressure line coming from the master cylinder. Connect the line going to the calipers to the "OUT" port.

Moving the adjuster lever until it is parallel with the body will provide full pressure delivery to the calipers. Moving the lever toward perpendicular to the body will incrementally reduce line pressure up to 57% when the valve is fully out. If this range of adjustment is not sufficient to properly balance the vehicle's bias, changes to other components within the system may be necessary.

TESTING THE SYSTEM - Do not attempt to operate the vehicle until the system has been fully tested under controlled conditions in a safe location. After the system has been bled, checked for leaks, and the proper pedal resistance and travel have been determined, make a series of low speed stops, then gradually progress to normal operating speeds.

WARNING - Adjustable proportioning valves are designed for tuning and balancing custom brake systems on performance, racing, and other types of special purpose vehicles. They are not designed as direct replacements for any OEM application.

4700 Calle Bolero • Camarillo, CA 93012 • Phone 805 / 388-1188 • www.wilwood.com

DS-489B REV DATE: 01-14-09