

## Hyper Chassis 600cc X4-X7 Setup Guide

### Suggested Starting Setup on a Normal Condition 1/6 or 1/8 Mile Track, Winged

	Left Front	Right Front	Left Rear	Right Rear
<b>Torsion Bar Size (+ Turns)</b>	.675 (+0)	.675 (+0)	.725 (+0)	.750 (+1)
<b>Coil Size (+ Turns)</b>	115 (+0)	125 (+0)		
<b>Block Size</b>	1-1/2"	1-1/2"	1-1/2"	1-1/2"
<b>Shock (Rebound/Compression)</b>	4/2	1/3	6/2	4.5/3
<b>Adjustable Shock*</b>	1-5/3.5 (-1 turn)	0.5-4/3 (-2-1/2)	7-2/2 (-1)	7-5/3 or 4.5/4.5-2 (-2)
<b>Monotube Pressure</b>	20 psi	20 psi	15 psi	15 psi
<b>Center Line of Tire Offset</b>		1" to the Right	12"	16"
<b>Tire Pressure</b>	9 psi	9 psi	5-8 psi	6-1/2-10 psi
<b>Tires</b>	57x6.0 RD12	57x6.0 RD12	62 or 63 x10 RD12	69Wx10 RD12
<b>Wheels</b>	10x7 (4" outer)	10x7 (4" outer)	10x10	10x13
<b>Stagger</b>	5" to 8-1/2"	* Adjustable shock turns are turns out from full stiff (full clockwise) **Use 2021 style Jacob's ladder frame tabs and start on the inner hole top and bottom.		
<b>Jacob's Ladder**</b>	Hole 3			
<b>Rear Panhard</b>	6-1/2"			
<b>Front Panhard</b>	3-1/4"			

### Suggested Starting Setup on a Slick Condition 1/6 or 1/8 Mile Track, Winged

	Left Front	Right Front	Left Rear	Right Rear
<b>Torsion Bar Size (+ Turns)</b>	.675 (+1-1/2)	.675 (+1)	.725 (+1-1/2)	.725 (+1-1/2)
<b>Coil Size (+ Turns)</b>	125 (+6)	125 (+4)		
<b>Block Size</b>	1-1/2"	1-1/2"	1-1/2"	1-1/2"
<b>Shock (Rebound/Compression)</b>	2	1/3	5/2	4.5/3
<b>Adjustable Shock*</b>	1-5/3.5 (-3)	0.5-4/3 (-5)	7-2/2 (-2)	7-5/3 (-1/2) or 4.5/4.5-2 (-4)
<b>Monotube Pressure</b>	20 psi	20 psi	15 psi	15 psi
<b>Center Line of Tire Offset</b>		1" to the Right	12"	16"
<b>Tire Pressure</b>	9 psi	9 psi	4-1/2" psi	5-1/2 psi
<b>Tires</b>	57x6.0 RD12	57x6.0 RD12	62 or 63 x10 RD12	69Wx10 RD12
<b>Wheels</b>	10x7 (4" outer)	10x7 (4" outer)	10x10	10x13
<b>Stagger</b>	5" to 6"	* Adjustable shock turns are turns out from full stiff (full clockwise) **Use 2021 style Jacob's ladder frame tabs and start on the inner hole top and bottom. Note: If LR is bottoming out on entry, stiffen the LR compression and use linear valving.		
<b>Jacob's Ladder**</b>	Hole 3 (maybe 5)			
<b>Rear Panhard</b>	5-1/2"			
<b>Front Panhard</b>	3-3/4"			

### Suggested Starting Setup on a Wet Condition 1/6 or 1/8 Mile Track, Winged

	Left Front	Right Front	Left Rear	Right Rear
Torsion Bar Size (+ Turns)	.650 (-1)	.675 (+0)	.725 (+0)	.775 (+0)
Coil Size (+ Turns)	105 (-4)	115 (+0)		
Block Size	2"	2"	2-1/4"	2-1/4"
Shock (Rebound/Comp) 5/2 3 7/2 4.5/4	5/2	3	7/2	4.5/4
Adjustable Shock*	1-5/3.5 (-1)	0.5-4/3 (-1/2)	7-2/2 (-0)	7-5/4 (-4) or 4.5/6-2 (-1/2)
Monotube Pressure	20 psi	20 psi	15 psi	45 psi
Center Line of Tire Offset		1-1/4" to the Right	12"	15-1/2" to 16-1/2"
Tire Pressure 9 psi 10 psi 6 psi 9-10 psi	9 psi	10 psi	6 psi	9-12 psi
Tires	57x6.0 RD12	57x6.0 RD12	63 x10 RD12	69Wx10 RD12
Wheels	10x7 (4" outer)	10x7 (4" outer)	10x10	10x13
Stagger	7-9"	* Adjustable shock turns are turns out from full stiff (full clockwise) **Use 2021 style Jacob's ladder frame tabs and start on the inner hole top and bottom.		
Jacob's Ladder**	Hole 3 (maybe 1)			
Rear Panhard	7"			
Front Panhard	3-1/4"			

### Suggested Starting Setup for Wingless

Follow the above setups for wingless with the following changes:

- Make sure you have enough counter steer. You will need more for wingless. **50 degrees** is needed.
- On 1/8 and 1/6 mile tracks, use 5" outer with 2" inner front wheels with the standard 40-1/2" front axle. This will make the front 2" wider, give more counter steer and more scrub radius to allow the kingpin angle to generate more LR weight with counter steer. With the 42" axle, use 4 on 3 front wheels or 5 on 2 on the LF. On big tracks, 1/4 mile or bigger, stick with the 4 on 3 on the RF and the 40-1/2" front axle but make sure you have enough counter steer.
- Run our multipoint Jacob's ladder in the 3-hole or 5-hole. This will tighten the car up on entry. On wet tracks stick with the 3 or maybe even the 1-hole position. Get the 2021 Jacob's ladder frame tab update and use the inner (left) most holes for almost all track conditions in combination with the 11" or 12" paddle. You must use the brake floater to do this. With the right side brake, you can only go to the 10-1/2" paddle. This helps significantly on cushions and bumps.
- Track conditions will affect a wingless car more than a winged. When adjusting for track conditions, go with more adjustment.
- For slick conditions, raise the car an extra turn (4 turns for coils) from the slick setup listed above. For extreme slick, go with 2-1/2 extra turns in the LR, +2 in RR, +2-1/2 (+10 coil) on LF and +2 (+8 coil) on RF.
- For normal and slick tracks for wingless, take much more of the left rear tie down out. You can go all the way down to full soft (2 valve). This will tighten the car up on entry. Or run a tight LR bump rubber with more tie down. Add shims to the bump rubber to tighten the car on exit.
- Front shocks should be full easy ups. A 0.5/2 or 0.5/3 front shocks for normal to slick conditions. Some drivers like the LF tied down some (like a 4/2).
- Right rear shock compression can vary from a 3 to a 7. On cushions, run more RR compression. Work with your shock builder on this. Rebound can vary from 4-6 on the right rear.

### On Larger Tracks

- *On larger tracks winged, more right rear weight is needed for corner entry due to the massive wing force that rolls the car left and unloads the right rear. Start with the Normal Condition setup listed above except add one more turn (+4 for coil) on the LF and RR.*
- *As the track slicks off raise the car and add even a little more right rear weight: +3LF, +1RF, +2-1/2RR, +1LR.*
- *Left front compression means a lot on larger tracks on corner entry. Use 3.5 on compression with linear or progressive valving on the left front to keep the weight on the right rear during the winged down phase.*
- *On tracks bigger than 1/3 mile, raising the car may actually loosen the car due to lateral traction being more important than longitudinal traction. Read the **Rethink Dirt: Advanced Dirt Track Theory** for more on this thought process.*

### X7 Shackle and Bearing Carrier Notes

- *Start with 3" RR and 4" LR shackles with the rod ends threaded in the whole way. Use the 40-400 Torsion Arm Standoff to allow proper shock travel. Without it, the shocks will not allow the chassis to get high enough. If you don't use the stand offs, use 2-1/2" RR and 3-1/2" LR shackles.*
- *Use the suggested block heights with the shackles in the middle hole of the X7 bearing carrier plates. Then you have the option of moving the shackle pin to the top hole instead of adding a turn for slick tracks. Move the shackle to the bottom hole on wet tracks instead of going to the 2" blocks. Doing this will keep the arm angle constant. Not a huge deal, but it helps.*
- *If you are documenting and comparing arm angles, keep in mind that block height, turns, tire pressure, tire offsets, fuel load, spring rates, driver, and other factors all play a role in the measured arm angle.*

### X7 Short Wheelbase Notes

*These notes apply only for the short wheel base (axle forward) configuration.*

- *Use the rear torsion arms with two shock mounts (forward and normal) and mount the shocks in the front hole. This will give the shocks more control over the added rear weight. If using the Torsion Arm Standoff (40-400) position the standoff so the shock is forward, and the standoff can be spun around for different shock positions.*
- *We found with the axle forward, because of the extra rear weight, the car will get better drive, but it will also get looser on entry. To counter this, we are carrying a new style wing 30-092 with no left side panel offset, both panels are back to help tighten the car on entry. We do not recommend this wing for the standard axle position.*
- *With winged racing and the axle forward, we found that stiffer rear bars are needed to counter the extra rear weight. We liked a .775RR and .725 LR.*
- *The axle forward position is only recommended for drivers lighter than 150 pounds because they suffer from a lack of rear weight bias. Heavier drivers using the axle forward position will experience a lot of inconsistency.*

### X7 Front Shock Sliders

- *To set the front shock sliders for wingless racing, jack the front of the car up, and make sure the front shocks are fully extended. Slide the clamps up or down so that the axle just touches the frame when the shocks are fully extended.*
- *For winged racing, use the same method as above except set the LF shock so the axle is 1" away from touching the frame. This will allow the LF frame corner to travel down further as the chassis wings left. On small real slick tracks winged, if you need more drive off, set the LF front shock in the wingless position, or go to 1/2" away from frame.*

### To Stop the Hop

- *A chassis hop in the turn is caused by too much right rear weight. The right rear can end up with massive amounts of dynamic weight transfer. All of this weight can cause the tire, which acts like a spring and has its own spring rate (but no shock to dampen it), to oscillate at a frequency. To reduce the hop, reduce the dynamic weight on the RR tire.*
- *How to do this? The best way is to add LF shock rebound, reduce LR rebound, move RR tire out, lower chassis (generally more on left side), or reduce RR compression. Other ways that also help: lower rear roll center, raise front roll center, add RR rebound, or move right side wishbone to lower hole.*

### Center of Gravity Height

- *CGH is huge and must be taken into consideration when making any adjustment to your chassis.*
- *Heavier drivers should raise the CGH of the car, and as a result, the chassis becomes tighter.*
- *For a driver heavier than 210-220 pounds keep the seat down on the bottom rail and use 750 LR and a 775 RR bars. Or at least block the car on 2" blocks, maybe even 2-1/2", but the risk is the chassis bottoming out.*
- *For a lightweight driver, less than 155-160 pounds, the car will tend to be looser. You will probably need to raise the seat to get proper CGH. Or maybe block the car with 1" blocks.*
- *Adding rebound on any corner will take weight off that corner anytime that shock is extending. Adding compression will add weight to that corner when that shock shaft is moving in.*
- *LR shock: less tie down (turns out, counter clockwise) will tighten up the car on entry, too much tie down will make the car hop through the turn, also too little tie down can make the car unpredictable harder to drive. It is a balance. Increase LR compression to tighten the car in the middle and on exit wingless, and to keep the car from bottoming out on entry with the wing on. Winged, too much LR compression will make the car too tight just after entry. We recommend about 50-55 pounds at 3"/sec with a linear increase in rate.*
- *RR shock: stiffen compression to loosen in middle and entry, stiffen rebound to tighten in middle.*
- *RF shock: stiffen compression to tighten in middle, stiffen rebound to loosen on exit.*
- *LF shock: stiffen rebound to help the drivability of the car on entry and through the middle. On slick tracks though, reduce LF rebound to get the car to raise up in the front quickly to get CGH up to transfer weight to the rear for drive. Also, for winged, LF compression can be a game winner. Increase it to tighten on entry since it will add RR weight to keep the weight equal on the rear tires for a tighter entry. We recommend a 3.5 on LF compression for winged racing.*

### Other Setup Notes

- *The suggested block heights are for use when the blocks are resting on the smallest diameter part of the axle. If using a 2" rear axle, use 1-1/2" blocks in the rear. If the blocks rest on the smaller diameter part of the spacer, subtract 1/8" from block height, if on larger diameter part of the spacer, subtract 1/4".*
- *Remember that with coil overs, you need to add 4 turns to make the same change as adding 1 turn on a torsion bar.*
- *Make sure your car is set up according to the squaring kit instructions with axles square, offset correct, and chain aligned. (Watch the squaring video on Hyper Racing's YouTube Channel.)*
- *Use a 32" wide nose wing where legal.*
- *For Jacobs ladder, start in the #3 position and the far-left hole on the top of the frame, and the middle hole on the bearing carrier plate.*
- *Set the top wing at 28 degrees on a 1/4 mile or smaller track to tighten up on exit. On bigger tracks go to about 22 degrees, and 18 degrees on really big track.*
- *Pay attention. If your car is bottoming out on entry, this can kill speed. A LR bump may be needed to keep the car from bottoming out on entry winged.*
- *If the car is not pointing in, (has a slight push when you first point the car in), add more RF weight by taking a 1/2 turn out of the LF and RR and adding a 1/2 turn to RF and LR.*
- *Tire preparation, grinding, grooving, and siping are essential to getting the most traction. See the **Setup Manual** or watch the tire prep video on **Hyper Racing's YouTube Channel**.)*
- *Treat monotube shock pressures like extra turns in that corner. The more pressure you run in a corner, the more weight. A 30psi change is similar to adding a turn. Shock pressure is in no way like running a stiffer bar or stiffer shock, it adds weight on that corner but does not change spring rate.*

### Jacobs Ladder

- *Our Multipoint Jacob's ladder can adjust the roll center right and left by 4". Generally, use the #3 hole for winged and the #5 hole for wingless. You can use the #1 hole on wet heavy tracks where you are trying to loosen the car. The #5 hole moves the roll center to the left the furthest and will make the car tighter.*
- *The 3 point Jacob's ladder end tab and the threaded holes in the bearing carrier plate can be used to move the roll center up and down by 2". Moving the rod end down or the end tab to the top hole (moves the paddle down) will lower the roll center and tighten the car.*

### To Make Car Tighter

- *Move wing back, and possibly add more angle.*
- *Reduce LR tie down to tighten up on entry.*
- *Lower RR tire pressures.*
- *Generally, add LR-RF weight to tighten up in middle and exit. This does not affect entry much on smaller tracks.*
- *Add LF RR weight to tighten up on entry on larger tracks.*
- *To make car tighter coming out (forward bite), raise ride heights front and rear. This is generally done on smaller tracks. Add 1 turn on all 4 corners to notice a change. Yes, raising the rear will provide more forward drive.*
- *Go to less stagger, as little as 4-1/2".*
- *Go to stiffer coils in the front, in extreme cases go to 140LF and 150RF. Only go this stiff if the track is smooth. Too stiff will cause the nose to push. A stiffer LF will tighten up on entry and going to a stiffer RF will tighten from the middle out.*
- *Lower the rear panhard bar, raise the front panhard bar.*
- *On a Jacob's ladder car, run it in the #5 position for wingless racing.*

### To Make Car Looser

- *Move wing front, but keep angle at 28 degrees on small track, use as large as possible nose wing (32" wide)*
- *Add more stagger (go to a 63 or 62x10, maybe even 61) this will achieve 6" to 9-1/2"*
- *Increase RR tire pressure to 8 to 10*
- *Move RR out to 16-1/2" or as far out as it will go, if car is rolling up on RR too much, extra 1" can be achieved by using a 9 on 4 RR wheel*
- *Raise rear panhard bar to as high as 8"*
- *On a Jacobs ladder car, move Jacob's ladder straps to the #1 position, this can really help on tacky rough tracks.*
- *To make car looser coming out lower ride heights, take 2 to 8 turns out of each front side and one to two turns out of each rear*
- *Stiffen up rear bars (.775LR, .800RR) in combination with lowering the car to keep it from bottoming out.*
- *Soften up coils in the front 95 LF and a 105 RF*
- *Install a rear traction bar if car is rolling too much. This is very common for heavy drivers.*

### RR Wishbone Height

*Starting with the X6 model chassis, a second, higher, right side wishbone mount was added. A different wishbone is needed for each mount. The higher mount will yield more drive as it will lift the car more on acceleration (more anti-squat). It will also steer the car more to the left as the car rolls right due to the rear axle being pushed back. This is most helpful when hitting a cushion or bump. The other side effect of this adjustment is that it will cause the longitudinal weight to transfer through the mechanical linkages instead of through the suspension springs and shocks. This can cause a harsh ride and increase the tendency of the car to hop.*

## Figure Out What You Really Want | The Phases of Adjustment

One of the hardest things about trying to get your car faster is trying to figure out what exactly you want your car to do. If you can figure that out, we can usually find a really good solution, but only if you know what you really want. Many times, racers want too much traction or too much of one thing. Be careful. As a driver, focus on getting the car right on the point in and entry phases first, if the car isn't right in these stages, the rest of the turn will never be good.

The diagram below attempts to divide the corner up into phases that best describe where adjustments will affect the handling of the car. Depending on track size, shape, and conditions, these phases of the turn can vary widely, so don't take them too literally. To better understand the adjustments and their effect on chassis handling, read **The Truth Behind the Adjustments** section later in this guide. Also, further your education by reading **Rethink Dirt: Advanced Dirt Track Theory** and **Shocks: A Mystery No More** on our website.

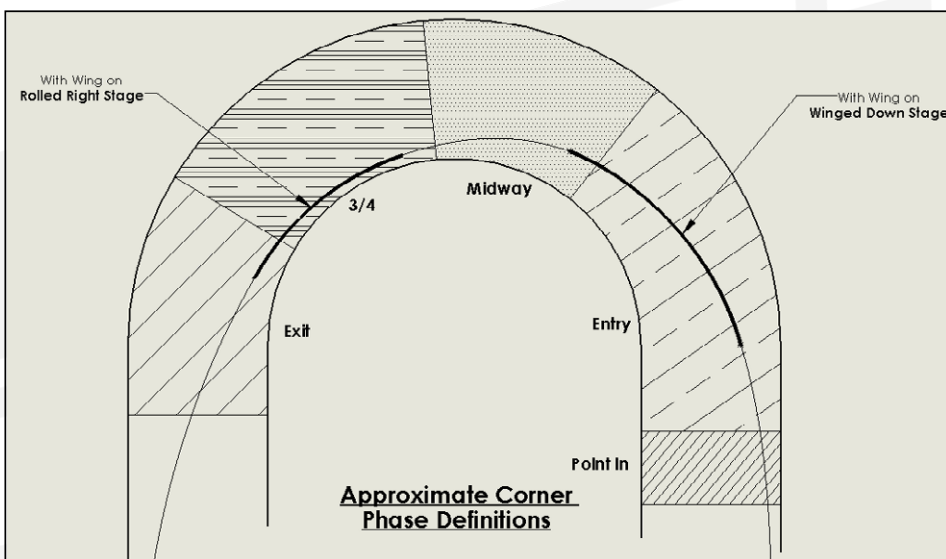

The adjustments we make to help the car in these phases of the turn can be drastically different depending on if the car is winged or wingless.

### Winged Down

A winged car adds two stages to the corner definitions. I call the first the **Winged Down Stage**. This is when the car rolls to the left due to the wing sideboards. This happens on corner entry. The bigger the track the longer the winged down stage will be. The way we adjust the car's right side springs to get the balanced roll couple for wingless is going to be applied to the left side springs and shocks to adjust the car during the winged down phase.

### Rolled Right

The second is the **Rolled Right Stage**, which occurs when the car slows enough that the lateral g-force on the car is greater than the side force generated by the wing panels. As a driver, you need to pay attention to how the car is working when it is winged left and rolled right and make your changes accordingly. The length of the winged down stage of the turn is different for each size and shape track, and it also changes during the night as the track goes slick. A track with tighter turns relative to the length of the straightaways will have more winged left effect, tracks that are larger will also have more winged left effect, and as the track gets slicker there is more winged down phase.

### Point In

The **Point In** phase is very short. It is that phase of the turn where the driver first turns the car to the left. Once the car points in, the driver will need to start counter steering. If the driver turns the car, but the car does not react, a push can occur for a small part or the whole way through the turn. Generally, a push during point in is caused by not enough weight on the right front. A car will never be loose in this phase.

If tight, add more static RF weight by adding turns to the RF, or take turns out of LF. Sometimes too much RF offset can cause this as well. A stiffer RF spring can help. Increasing wing angle can cause the car to do this as it causes the LR spring to compress unloading the RF. Adding RF/LR static weight or increasing the LR spring rate will help.

### Corner Entry

**Corner Entry** is the phase of the turn where the car is in transition the most.

In Wingless racing, this is the phase where the car is rolling from the left side to the right. If you start out with too much static LR weight, the car will be loose on entry until the weight transfers to the RR where the tires will be equally loaded and achieve maximum lateral traction. The slicker the track, the longer it takes the weight to transfer and the less amount of total weight transfers due to the reduced g-force (reference the formula). Right side springs, right side shock compression, left side rebound, and right side wheel offsets are all factors that matter.

In winged racing, this is where the very violent action of the car winging down left occurs. Pay attention to the car bottoming out on the LR during this phase. You may need to increase the LR shock high speed compression, increase the LR spring rate, or raise the LR ride height. LF compression, LF spring rate, LF & LR offset will all be big players in this phase with the wing on. Wing post height and sideboard location also matters.

### Midway

The **Midway Phase** is where the driver is getting back on the throttle or is back at full throttle. Lateral g-force is greatest here. The car is already rolled right, and the car's stance is pretty much set. Longitudinal traction becomes a bigger factor in this phase.

Ride heights and corner weights are important, and front rebound also plays a roll. Shock dampening in both rebound and compression can matter here, as the shocks never stop moving.

### 3/4 Phase and Corner Exit

**3/4 Phase** and the **Corner Exit Phase** are very close to the same: there is more lateral g-force during the 3/4 Phase. The driver plays a big role in 3/4 Phase as they are going to try to find bite in the track. Handling characteristics will change greatly depending on how well the driver can keep the car in the bite and how much they are asking the car to turn vs. accelerate forward.

Near the end of the 3/4 Phase is also where the car begins to roll left and back to neutral again as the lateral g-forces decrease. During this transition, the left side compression and right side rebound will have an effect.

CGH (ride heights) and rear weight bias are everything on corner exit. More rear weight and a higher car will always yield more longitudinal traction (forward bite). But don't forget all the factors that play into CGH dynamically. Anti-squat, spring rates, shock rates (both rebound and compression), seat height, engine mount height, tank tail mounting, etc. are all factors.

With the wing on, wing angle plays its biggest part in 3/4 and corner exit. More wing angle will get more weight on the rear of the car.

## The Truth Behind the Adjustments | Understanding Weight Transfer and Tire Efficiency

### THE 5 PRINCIPLES OF ENLIGHTENMENT

#### • Principle #1 Total Weight Transfer

Here are the formulas that describe how much total weight transfers from left to the right (lateral) side acceleration, and how much total weight transfers from the front to the rear (longitudinal), forward acceleration.

These are the only factors that affect the total amount of weight transfer due to the lateral and longitudinal g-forces. Nothing else matters. Many of our adjustments will affect the center of gravity height (CGH).

This is total weight transfer. Springs, shocks, and wheel offsets will determine to which corner the weight gets transferred.

$$\text{Longitudinal Weight Transfer} = \left( \frac{\text{Weight} \times \text{CGH}}{\text{Wheel Base}} \right) \times \text{Longitudinal G Force}$$

(front to back)

$$\text{Lateral Weight Transfer} = \left( \frac{\text{Weight} \times \text{CGH}}{\text{Track Width}} \right) \times \text{Lateral G Force}$$

(side to side)

#### • Principle #2 Tire Efficiency

The traction available from each tire is a function of how much weight is applied to it. More weight gives more traction, but the amount of increase in traction diminishes as more weight is applied. That's right, it diminishes. This principle is called tire efficiency and it looks like this:

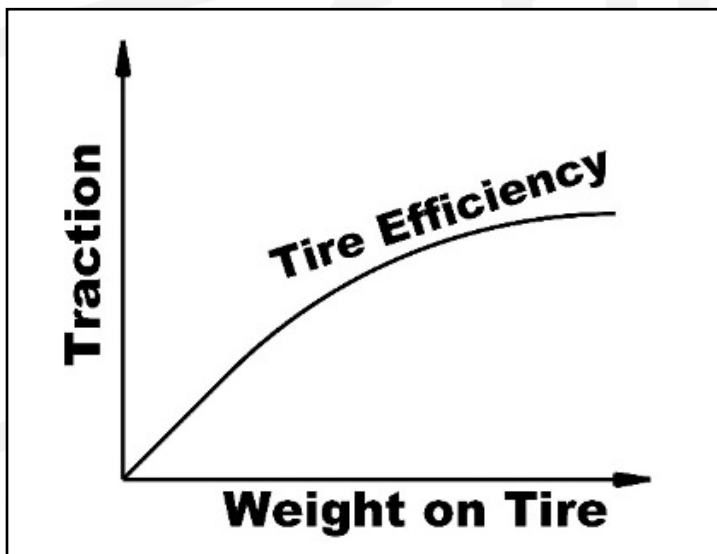



• **Principle #3 Maximum Traction**

Two tires with 100 pounds each will get more traction than the same two tires with one having 50 and the other having 150 pounds. This is a fact derived from the tire efficiency principle.

Maximum Lateral traction (side to side) occurs when all 4 tires are equally loaded. This is because of Tire Efficiency. As stated in the weight transfer formula, a lower CGH (lower ride heights) will give greater lateral traction because it will transfer less weight, while keeping the 4 tires more equally loaded.

Maximum Longitudinal traction (forward acceleration) occurs when the two rear tires are equally loaded and no weight is on the front tires. This assumes of course that it is a rear drive vehicle. As stated by the formula, a higher CGH will give greater longitudinal traction because more weight will transfer from the front to the rear.

Therefore, we can't have maximum lateral and longitudinal traction at the same time. When making an adjustment, you must first determine what you are asking the car to do. The adjustment will likely help one and hurt the other. Although both types of traction will benefit from the rear tires being more equally loaded.

• **Principle #4 Roll Couple**

Roll Couple determines which of the two tires the weight gets transferred to during lateral acceleration (side g-forces).

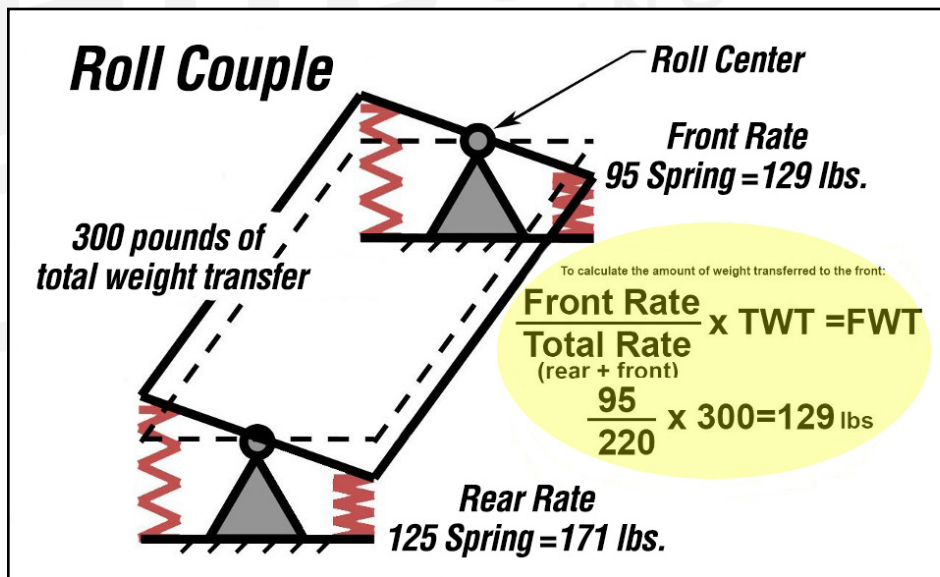

As we increase the right front spring rate, more weight will transfer to the right front and less to the right rear. The total weight transfer will remain the same.

A softer spring will transfer less weight to that corner of the car than a stiffer spring. Yes, the car will have more rear roll angle with a softer spring there, but it will be transferring less weight to the right rear. Note the statement of “more rear roll angle” and not “rolls more on the right rear”. Because it doesn't roll more on the right rear although there is more rear roll.

The same concept of roll couple on the front can be applied to rear roll. This is called pitch. Left and right rear spring rates will control which rear corner the longitudinal weight gets transferred to.

This is a simplified example as we really need to be looking at wheel rates and not spring rates directly. Wheel rate is a function of how far the wheel is from the spring (wheel offset from frame). But the concept is what is important to understand when making adjustments.

## • Principle #5 Geometric vs. Elastic Weight Transfer

Weight transferred through the springs is called elastic weight transfer. Weight transferred through the mechanical suspension parts like the panhard bar or Jacob's ladder is called geometric weight transfer.

Not all the weight transfer goes through the springs. Some of the weight gets transferred through the mechanical parts of the suspension like the Jacob's Ladder or the panhard bar. The bad thing about geometric weight transfer is that it does not go through the springs and can cause a harsh ride and cause the car hop and or loose grip.

Roll center height will have a large influence on how much the car will roll and which corner the weight will get transferred to. It will not change how much total weight is transferred. It will change how much lateral weight is transferred to the RF and the RR. The formulas get a bit more complex, but just know that as you raise the roll center at either the front or the rear, it will make that end transfer more of the total lateral weight.

You can figure out what percentage of weight is geometric by dividing the distance from the ground to the roll center and dividing it by the distance from the ground to the CG (see the diagram below).

Elastic weight transfer acts like a super stiff spring and the weight is transferred immediately where the elastic weight is transferred more slowly.

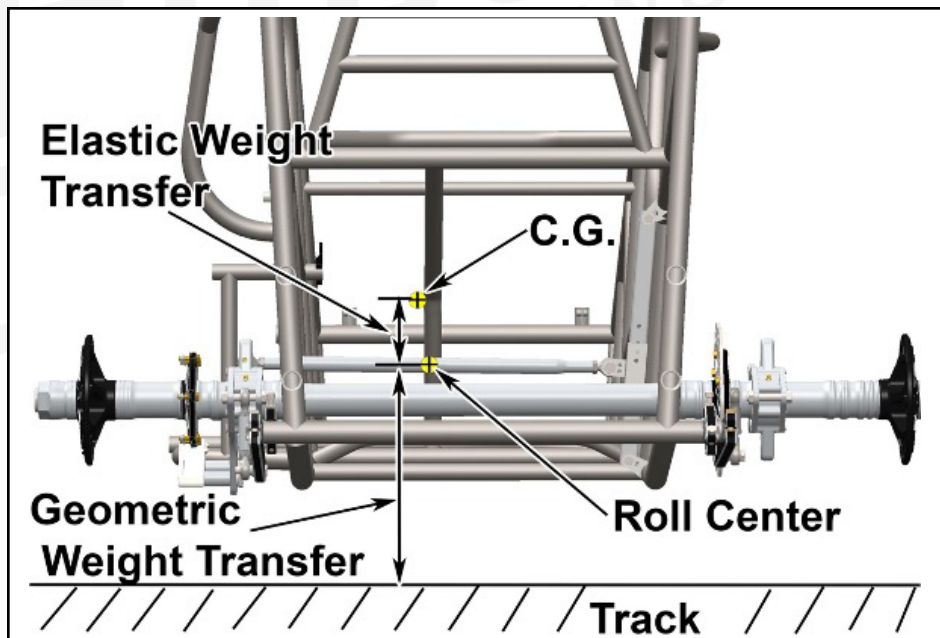

## Weight Transfer and Tire Efficiency: Conclusion

- As we increase the weight transfer from left to right, the car will get less lateral traction. As we increase weight transfer from front to back the car will get more traction when accelerating forward.
- For both lateral and longitudinal traction, as we keep the rear tires more equally loaded, traction will increase.
- As we increase the right front spring rate, the rear tires will be more equally loaded.
- Raising the rear roll center will transfer more of the total transferred weight to the rear, but the car will roll less. Lowering it will make the car roll more but transfer less weight to the rear. So lowering the rear roll center will create rear traction.

### Adjustments

Almost all suspension adjustments affect one of the 5 principles of enlightenment listed earlier. To figure out what handling characteristic the adjustment is going to change, consider its effect on the 5 principles.

**Primary Adjustments:** These adjustments directly affect one of the 5 principles. They are not any more important than secondary adjustment, they are just the prime mover.

- CGH (generally measured as ride heights)
- Total weight of the car
- Track width (wheel offsets)
- Wheel base
- Wheel rate (a direct function of spring rate and wheel offsets)
- Shock dampening direct loading on corner weight
  - If we add more rebound dampening force to a shock on a corner of a car it will cause that corner of the car to have less weight on it when that shock is in the rebound state.
  - Conversely If we add more compression dampening force to a shock on a corner of a car it will cause that corner of the car to have more weight on it when that shock is in the compression state.
  - This probably should be a secondary adjustment for the rear shocks as it has to be multiplied by the motion ratio determined by the mounting point on the rear arm.
- Static corner weights. Static weight is very minute compared to the amount of weight that is transferred through g-forces and shock dampening forces
- Aerodynamic loading (for winged car adjustment). How is the wing adjustment changing the tire loading? Consider the airfoil and the sideboards.
- Roll center heights

**Secondary Adjustments:** These adjustments will affect one of the adjustments listed above. Think about the adjustment you are making and what primary factors it is affecting.

- Stagger
- Tire compound, tire grooves, tire contact patch size, tire air pressure and its affect on CGH, corner weights, and the tire's inherent spring rate, tire width, side wall stiffness, tire diameter
- Other tire factors: Inherent spring rate and side wall stiffness. We have no control over these, but they do vary a lot between manufacturers.
- Camber
- Wheel alignment
- Spring rates (torsion arm length, arm angle, bar size, coil size). Spring rates have a direct effect on CGH and corner weights, both statically and dynamically.
- Shock dampening effect on CGH (stiffer compression shocks will hold the car higher at times)
- Shock gas pressure (corner weights and CGH)
- Shock angles (affects shock dampening rate ( $\cos^2$  of angle  $\times$  dampening force))
- King pin inclination, loads LR and RF when counter steer
- Wings effect on total W, CGH, corner weights (tire efficiency)
- Ride heights/block size/turns in torsion stops or coil over nuts and their effect on CGH and corner weights.
- Chain force
- All suspension mounting locations (roll center, pitch center, etc)
- Bearing carrier and shock mounting locations, specifically their distance from wheel